

AKC4926 stereo FM / TV / MW / SW / LW PVR radio tuner

Device Overview

AKC4926 Integrates a complete radio FM / TV sound / MW / SW receiver function, including input from the antenna to the stereo audio output of all modules. Chip supports worldwide FM / TV sound / long wave / MW / SW bands.

Features

- Support worldwide FM bands (64 ~ 108 MHz)
- stand by TV1 audio(56.25 ~ 91.75 MHz)
- stand by TV2 audio(174.75 ~ 222.25 MHz)
- Support wave band in the world (520 ~ 1730 KHz)
- Support worldwide shortwave bands (3.2 ~ 21.9 MHz)
- Worldwide support long-wave bands (150 ~ 285 KHz)
- It supports a wide supply voltage range: 2.0V ~ 3.6V
- stand by 32.768KHz Passive crystal
- Integrated audio amplifier (maximum power differential 0.6W)
- One kind of de-emphasis mode: 50us
- Support tuning lamp function
- stand by PVR Transfer station
- Audio inverted output
- Support for stereo line input
- Internal integrated PLL
- Intelligent frequency control
- AGC
- Precise digital demodulation
- Smart mute function
- MW Precise tuning adaptive front end
- integrated LDO
- According to the battery voltage, automatically adjust the volume
- Pb-free / RoHS compliant
- Support adjust the volume potentiometer
- In addition to the volume control potentiometer as well as 4 File preset volume gain

application

- Desktop radios, portable radios
- Clock radios
- Boom boxes

Package

- SSOP20L Package

Pin

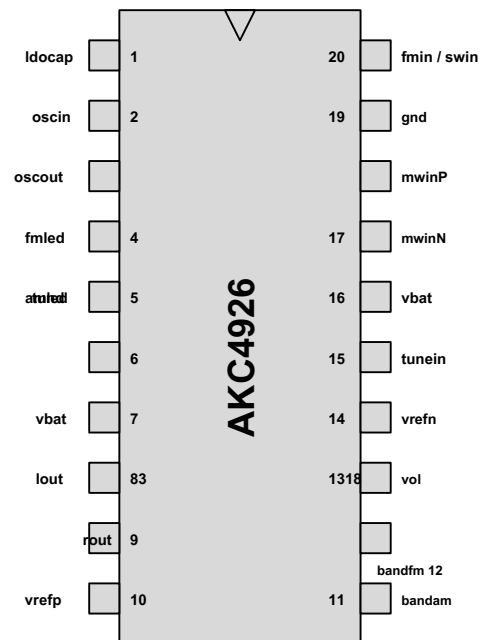

table of Contents

1 Technical Specifications 3

 1.1 Limit index 3

 1.2 Recommended operating conditions 3

 1.3 DC characteristics 3

 1.4 Reception characteristics 4

 1.4.1 FM and TV sound reception characteristics 4

 1.4.2 Medium wave and long wave reception characteristics 5

 1.4.3 Shortwave reception characteristics 5

 1.5 Crystal property requirements 5

2 Application Circuit 7

3 Pin definitions 8

 3.1 AKC4926 pin definition 8

4 Receiving TV sound 9

5 Chip set 4 File volume preset level. 9

6 How to configure band and mode of operation 9

7 SSOP 20L Package 13

1 Technical Specifications

1.1 Limit indicator

Table 1. Limit indicator

parameter	Symbols or test strips Item	Min	Typ	Max	unit
Power supply	VBAT	- 0.5	-	3.6	V
I2C interface input voltage	SCLK, SDIO	- 0.3	VBAT	VBAT + 0.3	V
Operating temperature		--20	-	85	° C
Storage temperature		- 55	-	150	° C
The maximum signal reception				0.8	Vpk
Pin antistatic			2		KV

Beyond the limits of the conditions listed above, it can cause permanent damage or deterioration indicator device.

1.2 Recommended operating conditions

Table 2. Recommended operating conditions

parameter	Symbols or Test Conditions	Min	Typ	Max	unit
Power supply	VBAT	2	3.3	3.6	V
Input digital signal low threshold	SCLK, SDIO			$0.3 * VBAT$	V
Input digital signal high threshold	SCLK, SDIO	$0.7 * VBAT$			
Low threshold output digital signal	SDIO, TUND			$0.2 * VBAT$	V
High threshold output digital signal	SDIO, TUND	$0.8 * VBAT$			V
Operating temperature		- 40	-	85	° C

1.3 DC Characteristics

(VBAT = 3V, VIO = 3 V, TA = 25 ° C, The other is the default, unless otherwise noted)

Table 3. DC Characteristics

parameter	Symbols or test conditions	Min	Typ	Max	Units
FM mode					
Working current	Built-in PA, do not take the horn	- 33			- mA
TV Sound Mode					
Working current	Built-in PA, do not take the horn	- 33			- mA
AM mode					
Working current	Built-in PA, do not take the horn	--32			- mA
Shortwave mode					
Working current	Built-in PA, do not take the horn	--32			- mA
SHUTDOWN mode					
Quiescent Current		--10			- μ A

1.4 Reception characteristics

(VBAT = 3V, TA = 25 ° C, The other is the default, unless otherwise noted)

1.4.1 FM and television sound reception characteristics

Table 4. FM reception characteristics

parameter name	symbol	Test Conditions	Typical minimum	value maximum	value unit	
FM Frequency Range	FM fr	Predefined band	64	-	108	MHz
TV1 Frequency Range	TV1 fr		56.25	-	91.75	MHz
TV2 Frequency Range	TV2 fr		174.25	-	222.25	MHz
Low noise amplifier input resistor	Zin		-	200	-	ohm
LNA input capacitance	Cin		-	2	-	pF
Sensitivity 1,2,3,5	Sen	SINAD = 26dB	-	2	-	<u>uV EMF</u>
Best signal to noise ratio 1,2,3,5,7	SNR		-	55	-	dB
Entry IP3 6			--	96	--	<u>dBuVEMF</u>
Stereo lighting sensitivity 4		pilot & stereo	-	twenty three	-	dBuV
Stereo separation 1,2,4,5		Pilot & Stereo	32	-	-	dB
Image Rejection	IMR	Mod = 22.5K <u>IMR = RF + 2 * IF SNR = 30dB</u>	-	43	-	dB
Adjacent channel selectivity		± 200K	-	50	-	dB
Selective channel spacing		± 400K	-	70	-	dB
AM suppression 1,2,3	AM suppression	AM mod = 30%	-	52	-	dB
Audio Frequency Response		- 3dB , De-emphasis closed	30	-	15K	Hz
Distortion 1,2,3,5,7,9	THD		-	0.1	-	%
$\Delta f = 22.5K$ Maximum power 1,2,3,5,7,8,10			-	400	- mW	
$\Delta f = 75K$ Maximum power 1,2,4,5,7,8,10			-	600	- mW	
The audio output common mode	Vcm		-	VDD / 2	-	V
Station search time			-	40	-	ms / chan
boot time		32.768K Crystal	-	1	-	ses
		12M Crystal	-	10	-	mS
The minimum operating voltage	MinV		-	2	-	V

Comment:

- 1.F MOD = 1KHz , 75uS de-emphasis
2. V EMF = 1mV, fr = 30MHz ~ 108MHz
3. $\Delta f = 22.5KHz$
4. $\Delta f = 75KHz$
5. The maximum test volume
6. $|f2-f1| > 2MHz, f0 = 2Xf1-f2$
7. Output pins test
8. Audio Load 8ohm
9. Audio Load 10K , 10pF
10. voltage 3.6V

1.4.2 Medium wave and long wave reception characteristics

Table 5. Polish and Long wave reception characteristics

parameter name	symbol	Test Conditions	Typical	minimum	value	maximum	value	unit
LW Frequency Range	LW _f	Predefined band	150	-	-	285	KHz	
MW Frequency Range	MW _f	Predefined band	510	-	-	1730	KHz	
Spatial sensitivity	Sen	Long bar magnet 80mm Lind = 350uH - 450uH SNR = 20dB	-	-	56	-	dBuV / m	
Signal to Noise Ratio	SNR	Mod = 30%	-	-	55	-	dB	
$\Delta f = 30\%$ power		VBAT = 3.6V	-	-	400	-	mW	
$\Delta f = 80\%$ power 2,3,4,6		VBAT = 3.6V	-	-	600	-	mW	
Audio Frequency Response		Mod = 30% Loss = 6dB	50	-	-	4000	Hz	
Distortion	THD	Mod = 30% 10Kohm load	-	-	0.1	-	%	
Antenna inductance value	MW		550	-	650	700	uH	
	LW		-	-	10	-	mH	
Output common mode	Vcm		-	-	VDD / 2	-	V	

1.4.3 Shortwave reception characteristics

Table 6. Shortwave reception characteristics

parameter name	symbol	Test Conditions	Typical	minimum	value	maximum	value	unit
Frequency Range	Fr	Predefined band	3.2	-	-	21.9	MHz	
Practical sensitivity	Sen	30% of modulation, SINAD = 26dB	-	-	twenty four	-	dBuV	
Signal to Noise Ratio	SNR	60dBuV, 30% of modulation	-	-	55	-	dB	
10KHz adjacent channel suppression system	ACS	30% of modulation, SINAD = 20dB	-	-	40	-	dB	
$\Delta f = 30\%$ power		VBAT = 3.6V	-	-	400	-	mW	
$\Delta f = 80\%$ power		VBAT = 3.6	-	-	600	-	mW	
Audio Frequency Response		Mod = 30% Loss = 6dB	50	-	-	4000	Hz	
Distortion	THD	Mod = 30% 10Kohm load	-	-	0.1	-	%	
Audio output common mode Voltage			-	-	VDD / 2	-		
Zapping time			-	-	35	-	us / chan	

1.5 Crystal property requirements

Table 7. Passive crystal properties

parameter name	symbol	Test Conditions	Typical	minimum	value	maximum	value	unit
32.768KHz Passive crystal Series resonant impedance	ESR					100		K Ω
Crystal frequency deviation			--100		0	100		ppm

Table 8. The active reference clock characteristics

parameter name	symbol	Test Conditions	Typical minimum value	maximum value	unit	
Rms jitter		Audio output SINAD more than the 40dB			2	ns
<u>Low voltage input reference clock</u>		Support sine and square wave	-0.1		0.4	V
<u>A high voltage input reference clock</u>		Support sine and square wave	1.2		1.8	V
Clock frequency deviation			--100	0	100	ppm

2 Application Circuit

Here is a 12 Pointer Band Radio Schematic:

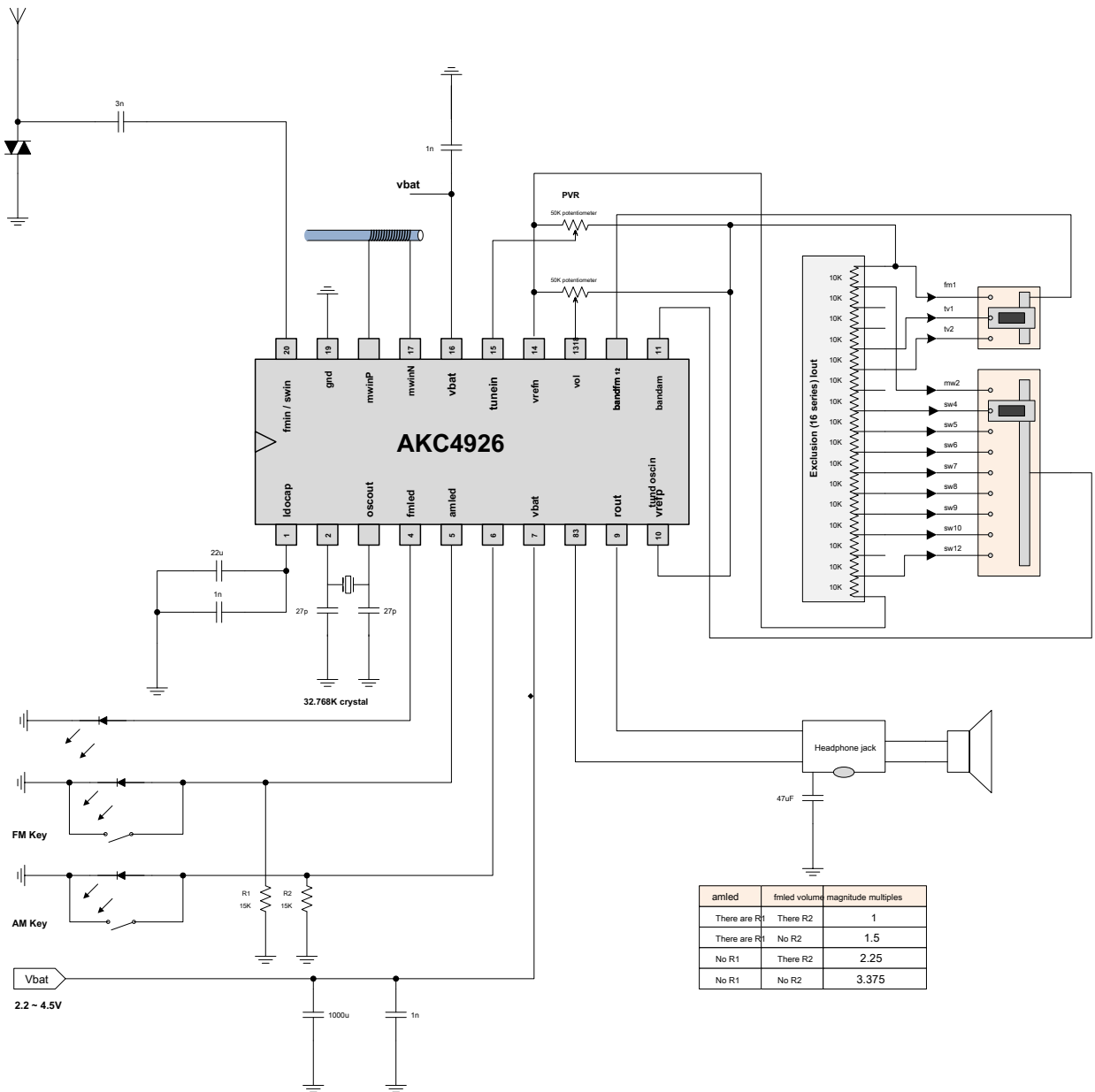

amlted	fmltd volume	magnitude multiples
There are R1	There R2	1
There are R1	No R2	1.5
No R1	There R2	2.25
No R1	No R2	3.375

3 Pin definitions

3.1 AKC4926 Pin definitions

Table 11. Pin Description

Pin Name	interpretation	
1	ldocap	Internal LDO output pin, nearest the need decoupling capacitors, recommendations 47uF
2	oscin	Bonding or passive 32.768K 12MHz crystal to ground, or receive an external clock reference signal
3	oscout	Passive other end connected to the crystal, when connected to an external clock, this pin floating
4	tund	Radio lock indicator pin, connected directly to the light emitting diode; Tuning the MCU software when the pin may also be used as a stop sign.
5	amled	AM and FM mode access lamp to be normally open key
6	fmled	FM mode and AM connected lamp to be normally open key
7	vbat	Then the power pins need to pay attention to the nearest ground 0.1uF decoupling capacitance to ground
8	lout	Left channel audio output
9	rout	Right channel audio output
10	vref_p	The reference output pin
11	band_am	AM band mode control pins, different bands corresponding to different voltages;
12	band_fm	FM band mode control pins, different voltages corresponding to the different wavelength bands;
13	vol	Variable volume potentiometer connected end, the fixed end of a potentiometer directly connected to VREF, and the other end through a resistor to ground. The resistance ratio of the resistor and potentiometer as 1: 2
14	vref_n	The reference output pin
15	tunein	Transfer station control pin
16	vbat	Then the power pins need to pay attention to the nearest ground 0.1uF decoupling capacitance to ground
17	mwinN	MW and LW signal input terminal
18	mwinP	
19	gnd	Close to ground
20	fmin / swin	FM radio frequency signal input terminal, note add blocking capacitor, 100pF recommendations

4 Receiving TV sound

TV sound fundamental difference with the general FM stations that sound is an odd multiple of 50KHz. Here are a few national television with audio points:

Table 13. TV with audio point

National television	TV channel 1 (MHz)			TV channel 2 (MHz)			TV Channel 3 (MHz)			TV Channel 4 (MHz)			TV Channel 5 (MHz)			TV Channel 6 (MHz)				
	Video	audio	video	audio	video	audio	Video	audio	video	audio	video	audio	Video	audio	video	audio	Video	audio	video	
China	49.75	56.25	57.75	64.25	65.75	72.25	77.25					83.75	85.25	91.75	168.25	174.75				
United States			55.25	59.75	61.25	65.75	67.25					71.75	77.25	81.75	83.25	87.75				
Australia Elijah	57.25	62.75	64.25	69.75	86.25	91.75	95.25					100.75	102.25	107.75	175.25	180.75				
new Zealand	45.25	50.75	55.25	60.75	62.25	67.75	175.25	180.75	182.25	187.75	189.25	194.75								
Indonesia	48.25	53.75	55.25	60.75	62.25	67.75	175.25	180.75	182.75	187.75	189.25	194.75								
Italy	53.75	59.25	62.25	67.75	82.25	87.75	175.25	180.75	183.25	188.75	192.25	197.75								
CCIR 4	41.25	46.75	48.25	53.75	55.25	60.75	62.25					67.75	175.25	180.75	182.25	187.75				

5 Chip set 4 File volume preset level.

amled	fmled	Volume amplitude magnification
There 15K resistor to ground	There 15K resistor to ground	1
There 15K resistor to ground	no	1.5
no	There 15K resistor to ground	2.25
no	no	3.375

6 How to configure band and mode of operation

There are two modes of operation of the chip patterns and band:

Embodiment 1: Operating modes are determined mode button, working with a specific band determined band_am and band_fm pin, and this mode of operation requires band_am band_fm can not be grounded. DETAILED operating band in this manner there are respectively connected to the above voltage band_am band_fm and decision, the chip 19 is designed voltage level, the following table and the correspondence between the voltage level of the band:

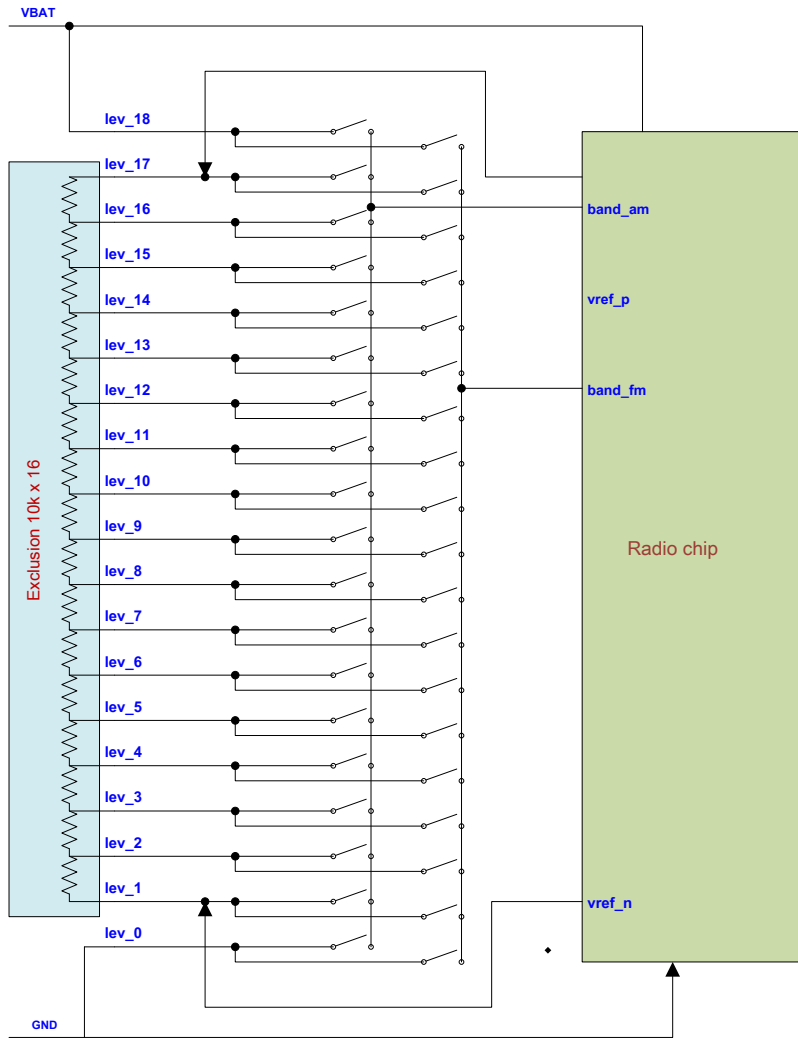

Voltage level	band_am		band_fm	
lev_18	MW3	0.52M ~ 1.71M, 5K channel number, 10K station search	FM2	~ 108M
	MW2	0.522M ~ 1.62M, 3K channel number, 9K station search	way	~ 108M
lev_16	MW4	0.52M ~ 1.73M, 5K channel number, 10K station search	FM3	70M ~ 93M
lev_15	MW1	0.52M ~ 1.71M, 5K channel number, 5K station search	FM4	76M ~ 90M
lev_14	LW	0.15M ~ 0.285M, 3K channel number, 3K station search	FM5	64M ~ 88M 76M
lev_13	SW1	Split mode, is sw3, sw4, sw5, sw6 sum	TV1	56.25M ~ 91.75M 87M
lev_12	SW2	3.2M ~ 4.1M, 5K channel number, 5K station search	TV2	174.75M ~ 222.25M
lev_11	SW3	4.7M ~ 5.6M, 5K channel number, 5K station search	FM6	87.3M ~ 108.2M
lev_10	SW4	5.7M ~ 6.4M, 5K channel number, 5K station search	FM7	86.5M ~ 109M
lev_9	SW5	6.8M ~ 7.6M, 5K channel number, 5K station search	FM1	87M ~ 108M
lev_8	SW6	9.2M ~ 10M, 5K channel number, 5K station search	FM1	87M ~ 108M
lev_7	SW7	11.4M ~ 12.2M, 5K channel number, 5K station search	FM1	87M ~ 108M
lev_6	SW8	13.5M ~ 14.3M, 5K channel number, 5K station search	FM1	87M ~ 108M
lev_5	SW9	15M ~ 15.9M, 5K channel number, 5K station search	FM1	87M ~ 108M
lev_4	SW10	17.4M ~ 17.9M, 5K channel number, 5K station search	FM1	87M ~ 108M
lev_3	SW11	18.9M ~ 19.7M, 5K channel number, 5K station search	FM1	87M ~ 108M
lev_2	SW12	21.4M ~ 21.9M, 5K channel number, 5K station search	FM1	87M ~ 108M
lev_1	SW13	Split mode, is sw7, sw8, sw9, sw10 sum	FM3	87M ~ 108M
lev_0	reserved		2 FM1	

♦

Mode 2: Work mode and working bands all have band_am decision, this mode requires band_fm to the ground. The following table is a correspondence relationship with the voltage level of the band in this manner band_am contact:

Voltage level	band_am	
lev_18	FM1	87M ~ 108M
	FM3	70M ~ 93M
lev_16	TV1	56.25M ~ 91.75M
lev_15	TV2	174.75M ~ 222.25M
lev_14	MW2	0.522M ~ 1.62M, 3K channel number, 9K station search
lev_13	SW1	Split mode, is sw3, sw4, sw5, sw6 sum
lev_12	SW2	3.2M ~ 4.1M, 5K channel number, 5K station search
lev_11	SW3	4.7M ~ 5.6M, 5K channel number, 5K station search
lev_10	SW4	5.7M ~ 6.4M, 5K channel number, 5K station search
lev_9	SW5	6.8M ~ 7.6M, 5K channel number, 5K station search
lev_8	SW6	9.2M ~ 10M, 5K channel number, 5K station search
lev_7	SW7	11.4M ~ 12.2M, 5K channel number, 5K station search
lev_6	SW8	13.5M ~ 14.3M, 5K channel number, 5K station search
lev_5	SW9	15M ~ 15.9M, 5K channel number, 5K station search
lev_4	SW10	17.4M ~ 17.9M, 5K channel number, 5K station search
lev_3	SW11	18.9M ~ 19.7M, 5K channel number, 5K station search
lev_2	SW12	21.4M ~ 21.9M, 5K channel number, 5K station search
lev_1	SW13	Split mode, is sw7, sw8, sw9, sw10 sum
lev_0	reserved	

7 SSOP 20L Package

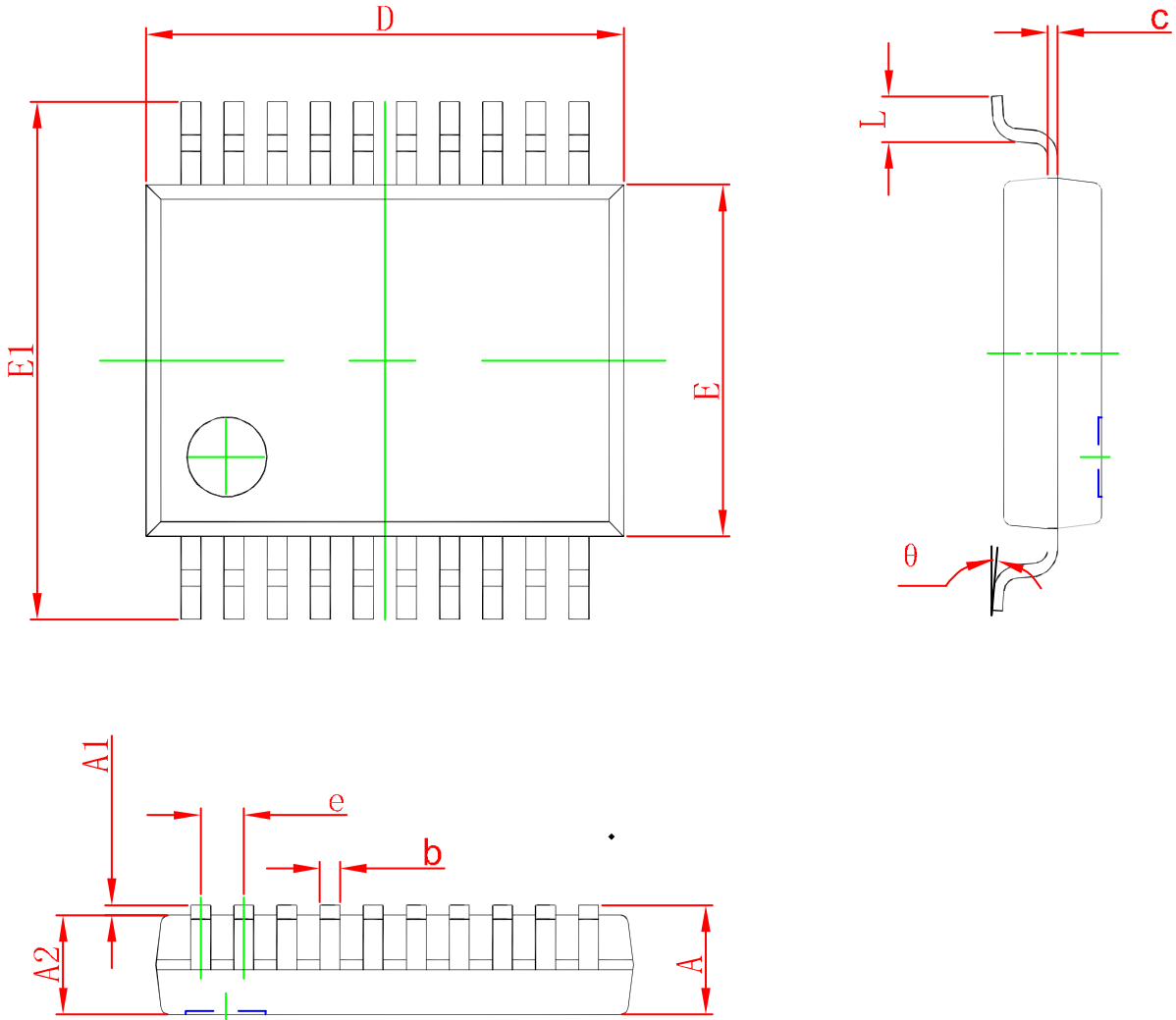

Symbol	Dimensions in Millimeters Min	
		Max
A		1.85
A1	0.05	0.25
A2	1.4	1.6
b	0.29	0.37
c	0.15	0.20
D	7.0	7.4
E	5.1	5.5
E1	7.6	8.0
e	0.65BSC	
L	0.75	1.05
θ	0	8°